



C:\ProgramData\Bentley\OpenRoads Designer\2024.00\Configuration\WorkSpaces\OH\DOTCEv02\_24.0\WorkSetCFGs\COS-10247-0001\_BridgeReplacement\400-Engineering\Drainage\Sheets\2025.11.03\_COS-10247-0001\_GeneralNotes&Summary.dgn

**UTILITIES**

THE CONTRACTOR SHALL NOTIFY THE OHIO UTILITIES PROTECTION SERVICE (OUPS) AT LEAST TWO (2) WORKING DAYS PRIOR TO EXCAVATION. THE CONTRACTOR SHALL PROVIDE THE ENGINEER WITH ALL OUPS REFERENCE NUMBERS FOR THIS PROJECT. ALL UTILITY RELOCATION, REMOVAL, OR NEW CONSTRUCTION SHALL BE PERFORMED BY AND AT THE EXPENSE OF THE RESPECTIVE UTILITY OWNER, UNLESS OTHERWISE NOTED IN THE PLANS. THE CONTRACTOR SHALL COORDINATE OPERATIONS WITH UTILITY OWNERS TO MINIMIZE CONFLICTS AND DELAYS. AERIAL LINES THAT REQUIRE TEMPORARY DROPPING FOR PLACEMENT OF CULVERT SECTIONS SHALL BE COORDINATED BY THE CONTRACTOR TO MINIMIZE INCONVENIENCE TO ALL PARTIES.

**STANDARD DRAWINGS**

REFERENCE SHOULD BE MADE TO THE MOST CURRENT ODOT STANDARD DRAWINGS SHOWN IN THE TABLE ON THE COVER SHEET.

**BEST MANAGEMENT PRACTICES**

BEST MANAGEMENT PRACTICES (BMP'S) FOR SOIL EROSION AND SEDIMENT CONTROL SPECIFICATIONS SET FORTH IN THE MOST CURRENT VERSION OF ODOT'S CONSTRUCTION AND MATERIAL SPECIFICATIONS (CMS), LOCATION AND DESIGN MANUAL, SUPPLEMENTAL SPECIFICATION 832, AND STANDARD DRAWINGS" SHALL BE USED TO ENSURE ADEQUATE EROSION AND SEDIMENT CONTROL, ALONG WITH ADDITIONAL PROTECTIVE MEASURES TO AVOID IMPACT TO ADJACENT PROPERTIES AND WETLANDS FROM CONSTRUCTION ACTIVITIES. EROSION/SEDIMENTATION IMPACTS SHALL BE KEPT TO A MINIMUM THROUGH THE USE OF BMP'S FOR SOIL EROSION AND SEDIMENTATION CONTROL. ALL SOIL EROSION AND SEDIMENT CONTROL MEASURES AS SPECIFIED IN THE PLAN SHALL BE IN PLACE PRIOR TO ANY EXCAVATION, GRADING OR FILLING OPERATIONS AND INSTALLATION OF PROPOSED STRUCTURES OR UTILITIES. THEY SHALL REMAIN IN PLACE UNTIL CONSTRUCTION IS COMPLETE AND THE AREA STABILIZED AS ACCEPTED BY THE ENGINEER. THEY SHALL ALSO COMPLY WITH ODOT'S "HANDBOOK OF SEDIMENT AND EROSION CONTROL".

**TEMPORARY EROSION CONTROL REMOVAL**

ALL TEMPORARY EROSION CONTROL ITEMS SHALL BE REMOVED BEFORE THE PROJECT IS ACCEPTED. REMOVED MATERIAL SHALL BECOME THE PROPERTY OF THE CONTRACTOR AND SHALL BE DISPOSED OF IN ACCORDANCE WITH THE APPROPRIATE CMS SPECIFICATIONS

**RIGHT OF WAY (ROW)**

ALL WORK SHALL BE PERFORMED WITHIN THE EXISTING RIGHT-OF-WAY, UNLESS OTHERWISE NOTED IN THESE PLANS.

**STRUCTURE DESIGN SUBMITTAL**

THE REINFORCED CONCRETE BOX CULVERT SHALL BE DESIGNED, MANUFACTURED AND INSTALLED IN ACCORDANCE WITH CMS ITEM 611 AND SUPPLEMENT 1002.

THE MANUFACTURER SHALL SUBMIT SHOP DRAWINGS, DESIGN CALCULATIONS, AND LOAD RATING (INCLUDING THE BRR DIGITAL MODEL) DOCUMENTATION SEALED BY A PROFESSIONAL ENGINEER LICENSED IN OHIO.

THE DESIGN SHALL CONFORM TO THE CURRENT AASHTO LRFD BRIDGE DESIGN SPECIFICATIONS AND THE ODOT BRIDGE DESIGN MANUAL, AND SHALL ACCOMMODATE HL-93 LIVE LOADING PLUS 60 PSF FUTURE WEARING SURFACE.

CONCRETE AND REINFORCEMENT SHALL MEET THE REQUIREMENTS OF CMS ITEM 706.05.

**WATERPROOFING**

APPLY TYPE 2 MEMBRANE WATERPROOFING IN ACCORDANCE WITH CMS ITEM 512.08 AND 711.25. APPLY TO THE ENTIRE EXTERIOR TOP AND SIDES OF THE PRECAST BOX CULVERT. EXTEND 1 FOOT 6 INCHES PAST THE WINGWALL/CULVERT JOINT. PAYMENT UNDER ITEM 512 - TYPE 2 WATERPROOFING, PER SQUARE YARD.

**ITEM 202 STRUCTURE REMOVAL, AS PER PLAN**

REMOVE EXISTING STRUCTURE ACCORDING TO CMS 202.03. IF PRESENT, THE COUNTY WILL RETAIN OWNERSHIP OF ALL CUT SANDSTONE. THE CONTRACTOR SHALL COORDINATE THE HANDLING AND REMOVAL OF ANY CUT SANDSTONE WITH THE COUNTY. ALL REMAINING MATERIAL SHALL BE THE CONTRACTOR'S RESPONSIBILITY FOR DISPOSAL.

**ITEM 602 MASONRY MISCELLANEOUS: PRECAST CONCRETE BLOCK, AS PER PLAN**

THE WINGWALLS SHALL BE PRECAST CONCRETE BLOCKS WITH STONE TEXTURED FACE. THE BLOCKS SHALL BE INSTALLED PER MANUFACTURER'S SPECIFICATIONS AND SHALL BE PAID FOR UNDER THE LUMP SUM FEE FOR ITEM 602 MASONRY MISCELLANEOUS: PRECAST CONCRETE BLOCK. BLOCK GROUND REINFORCING, IF REQUIRED BY THE MANUFACTURER, SHALL BE INSTALLED AS PER THE MANUFACTURER'S REQUIREMENTS. THIS ITEM SHALL INCLUDE ALL MATERIALS AND LABOR, INCLUDING AGGREGATE LEVELING PAD, GROUND REINFORCING (IF REQUIRED), DRAIN PIPE, AND INCIDENTAL ITEMS NECESSARY TO COMPLETE THE INSTALLATION.

**ITEM 614 MAINTENANCE OF TRAFFIC**

MAINTENANCE OF TRAFFIC IN ACCORDANCE WITH CMS ITEM 614 AND THE OHIO MANUAL OF UNIFORM TRAFFIC CONTROL DEVICES. IF A DETOUR IS REQUIRED, THE CONTRACTOR SHALL FURNISH, ERECT, MAINTAIN, AND REMOVE ALL DETOUR SIGNING, INCLUDED UNDER ITEM 614.

**ITEM 659 SEEDING AND MULCHING, AS PER PLAN**

ALL DISTURBED AREAS SHALL BE SEEDED AND MULCHED IN ACCORDANCE WITH CMS ITEM 659. APPLY 2 INCHES MINIMUM OF TOPSOIL PRIOR TO SEEDING UNLESS OTHERWISE DIRECTED. IN AREAS DESIGNATED TO RECEIVE EROSION CONTROL MATS (ECM), TYPE C, PREPARE, SEED, FERTILIZE, AND MULCH PRIOR TO PLACEMENT. INSTALL ECM IN ACCORDANCE WITH CMS ITEM 671 AND MANUFACTURER'S RECOMMENDATIONS, ANCHOR AT CREST AND TOE. PAYMENT FOR SEEDING AND MULCH SHALL BE UNDER ITEM 659; PAYMENT FOR ECM SHALL BE UNDER ITEM 671.

ITEM	DESCRIPTION	UNIT	QUANTITY
201	CLEARING AND GRUBBING	LS	1
202	STRUCTURE REMOVED, AS PER PLAN	LS	1
203	EXCAVATION	CY	10
203	EMBANKMENT	CY	110
304	AGGREGATE BASE	CY	25
503	COFFERDAMS AND EXCAVATION BRACING	LS	1
503	UNCLASSIFIED EXCAVATION, INCLUDING ROCK	LS	1
509	EPOXY COATED REINFORCING STEEL	LF	452
511	CLASS QC1 CONCRETE, CUT OFF WALL	CY	9
512	TYPE 2 WATERPROOFING	SY	129
601	ROCK CHANNEL PROTECTION, TYPE B	CY	45
602	MASONRY, MISCELLANEOUS: PRECAST CONCRETE BLOCK, AS PER PLAN	LS	1
611	9' X 6' CONDUIT, TYPE A, 706.05, AS PER PLAN	FT	40
613	LOW STRENGTH MORTAR BACKFILL	CY	120
614	MAINTENANCE OF TRAFFIC	LS	1
623	CONSTRUCTION LAYOUT AND SURVEYING	LS	1
624	MOBILIZATION	LS	1
659	SEEDING AND MULCHING, CLASS 1, AS PER PLAN	LS	1
671	EROSION CONTROL MAT, TYPE C	SY	90
832	EROSION CONTROL	LS	1

\*THE ESTIMATED QUANTITIES PROVIDED ABOVE ARE FOR INFORMATIONAL PURPOSES ONLY AND ARE NOT GUARANTEED. THE CONTRACTOR IS RESPONSIBLE FOR VERIFYING ALL QUANTITIES AND FIELD CONDITIONS PRIOR TO BIDDING AND CONSTRUCTION. ANY DISCREPANCIES OR ADDITIONAL QUANTITIES REQUIRED TO COMPLETE THE WORK AS PER THE PLANS AND SPECIFICATIONS SHALL BE ADDRESSED IN ACCORDANCE WITH THE CONTRACT TERMS.

GENERAL NOTES AND SUMMARY  
TR 247 BRIDGE 1 REPLACEMENT

COSHOCKTON COUNTY  
ENGINEER'S OFFICE  
(740) 632-2135 FAX: (740) 623-6512

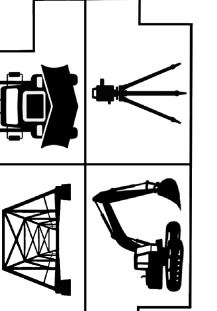

DESIGNER	CJS
REVIEWER	JDK
PROJECT ID	04-07-26
	2025050102
SHEET	TOTAL
2	7

C:\ProgramData\Bentley\OpenRoads Designer\2024.00\Configuration\WorkSpaces\OHDOTCEv02\_24.0\WorkSetCFGs\COS-T0247-0001\_BridgeReplacement\400-Engineering\Drainage\Basemaps\2026.01.14\_COS-T0247-0001\_RoadwayPlan.dgn

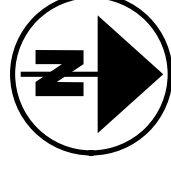

COUNTY ROAD 103

0+00

BEGIN WIDENING  
0+55.87, 8.51' LT

EXISTING FENCE TO BE REMOVED AND REPLACED  
CONTRACTOR TO COORDINATE WITH LANDOWNER

EXISTING EDGE  
OF GRAVEL ROAD

PROPOSED EDGE OF GRAVEL ROAD  
WIDEN WITH MINIMUM - 6" ODOT 304  
AGGREGATE BASE ON COMPACTED SUBGRADE

1+00

MATCHLINE STA. 1+12.50 (SEE SHEET 4 / 7)

BEGIN WIDENING  
0+69.84, 8.12' RT

834'

844

840

846

835

838

835

832

830

3:1

6:1

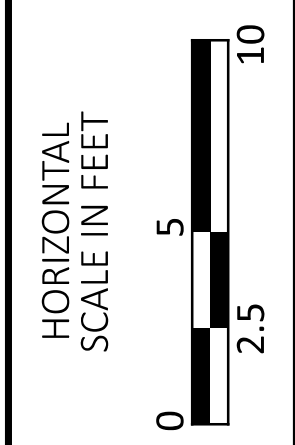

# ROADWAY AND GRADING PLAN TR 247 BRIDGE 1 REPLACEMENT

COSHOCTON COUNTY  
ENGINEER'S OFFICE  
(740) 632-2135 FAX: (740) 623-6512

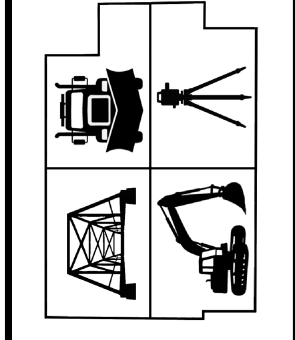

DESIGNER	CJS
REVIEWER	JDK
PROJECT ID	04-07-26
	2025050102
SHEET	TOTAL
3	7

C:\ProgramData\Bentley\OpenRoads Designer\2024.00\Configuration\WorkSpaces\OHDOTCEv02\_24.0\WorkSetCFGs\COS-T0247-0001\_BridgeReplacement\400-Engineering\Drainage\Basemaps\2026.01.14\_COS-T0247-0001\_RoadwayPlan.dgn

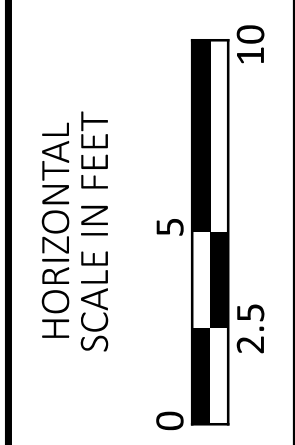
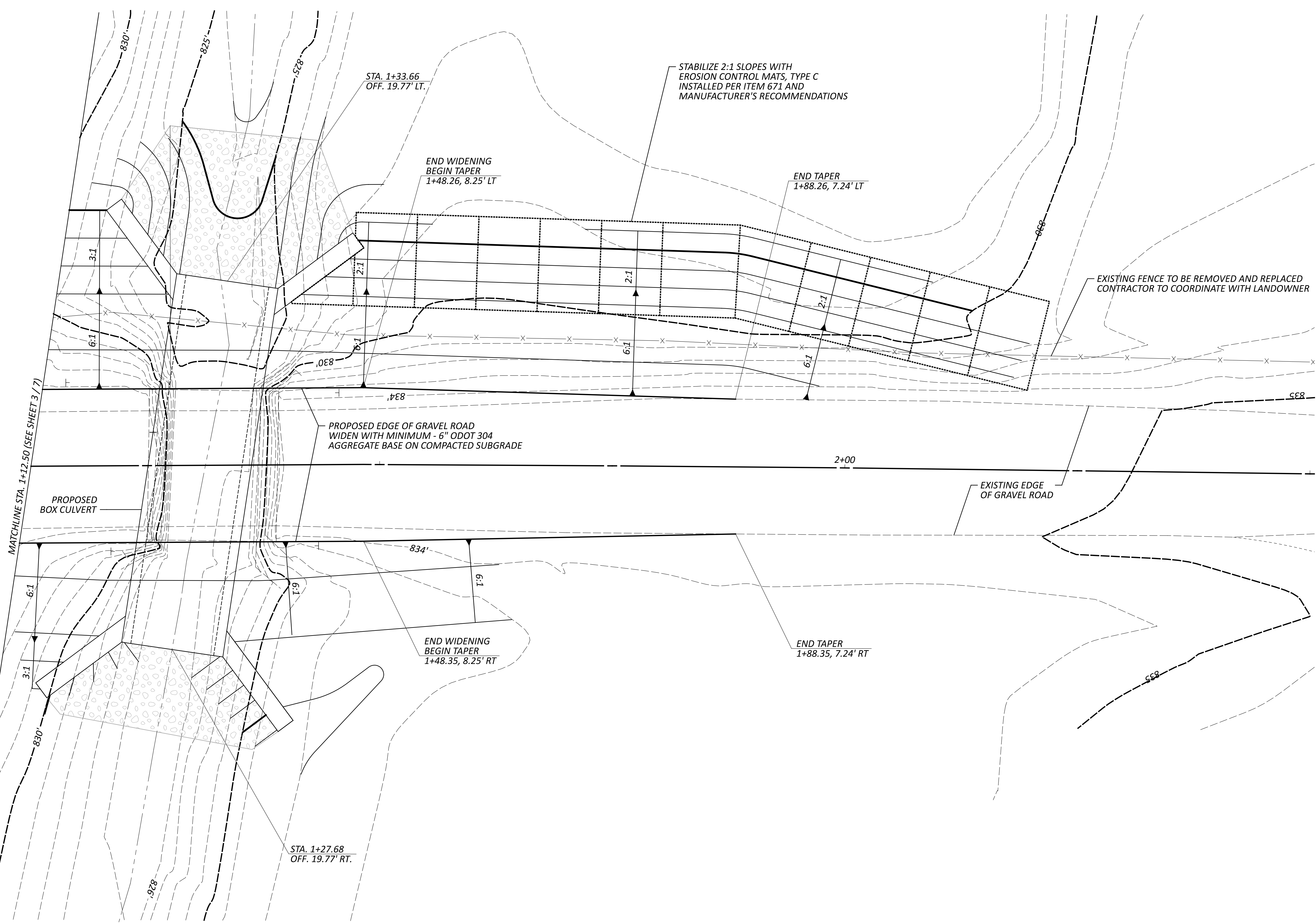
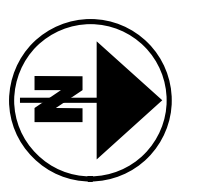

**ROADWAY AND GRADING PLAN  
TR 247 BRIDGE 1 REPLACEMENT**

COSHOCTON COUNTY  
ENGINEER'S OFFICE  
(740) 632-2135 FAX: (740) 623-6512

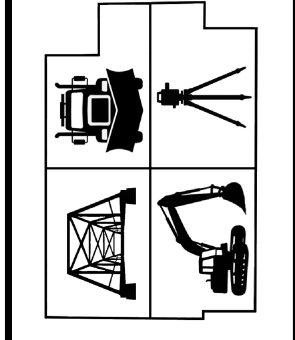

DESIGNER	CJS
REVIEWER	JDK
PROJECT ID	04-07-26
	2025050102
SHEET	TOTAL
4	7

C:\ProgramData\Bentley\OpenRoads Designer\2024.00\Configuration\Workspaces\OHDOTCEv02\_24\_0\WorksetCFGs\COS-T0247-0001\_BridgeReplacement\400-Engineering\Drawings\Basemaps\2026.01.14\_COS-T0247-0001\_Culvert Plan and Profile.dgn

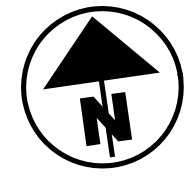

ROCK CHANNEL PROTECTION, TYPE B  
 PROVIDE APRON 16' LONG, TAPERED  
 FROM THE HEADWALLS TO A 16' WIDTH.  
 THICKNESS 30" MINIMUM. GRADE APRON  
 TO NEAT LINES AND FEATHER EXISTING GRADE.

PROPOSED EDGE OF GRAVEL ROAD  
 WIDEN WITH MINIMUM - 6" ODOT 304  
 AGGREGATE BASE ON COMPACTED SUBGRADE  
 (SEE SHEETS 3-4 FOR WIDENING LIMITS)

BENCHMARK DATA SPC (3401 OH N)	
CP 100: 3/4" REBAR w/ PLASTIC CAP MARKED "COSHOCOTON CNTY ENGINEER"	
NORTHING:	241,663.744
EASTING:	2,209,217.384
ELEVATION:	851.386
LOCATED 130' SOUTHEAST OF THE INTERSECTION OF CR 103 & TR 247	

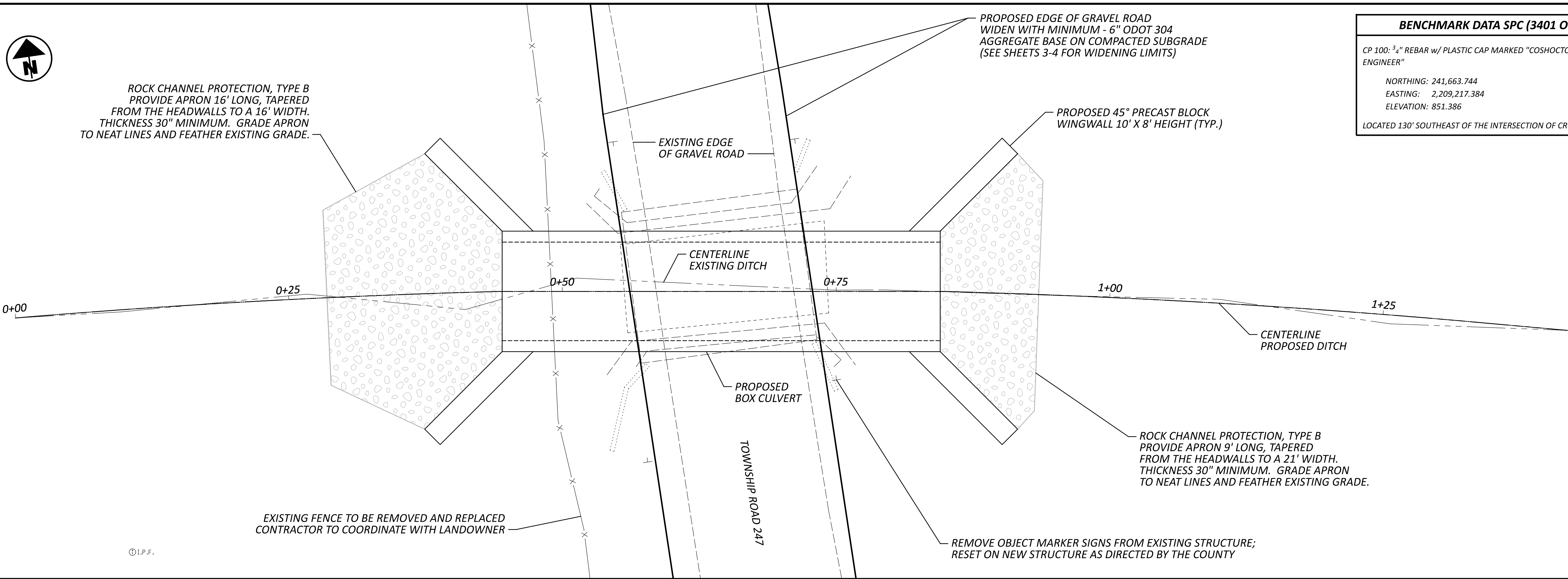
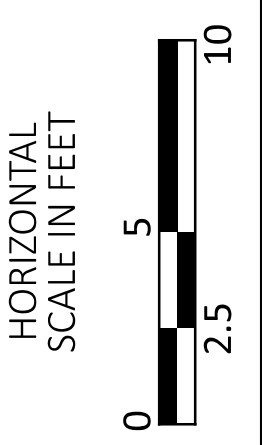

EXISTING FENCE TO BE REMOVED AND REPLACED  
 CONTRACTOR TO COORDINATE WITH LANDOWNER

REMOVE OBJECT MARKER SIGNS FROM EXISTING STRUCTURE;  
 RESET ON NEW STRUCTURE AS DIRECTED BY THE COUNTY

© I.P.F.

CULVERT PLAN AND PROFILE  
 TR 247 BRIDGE 1 REPLACEMENT

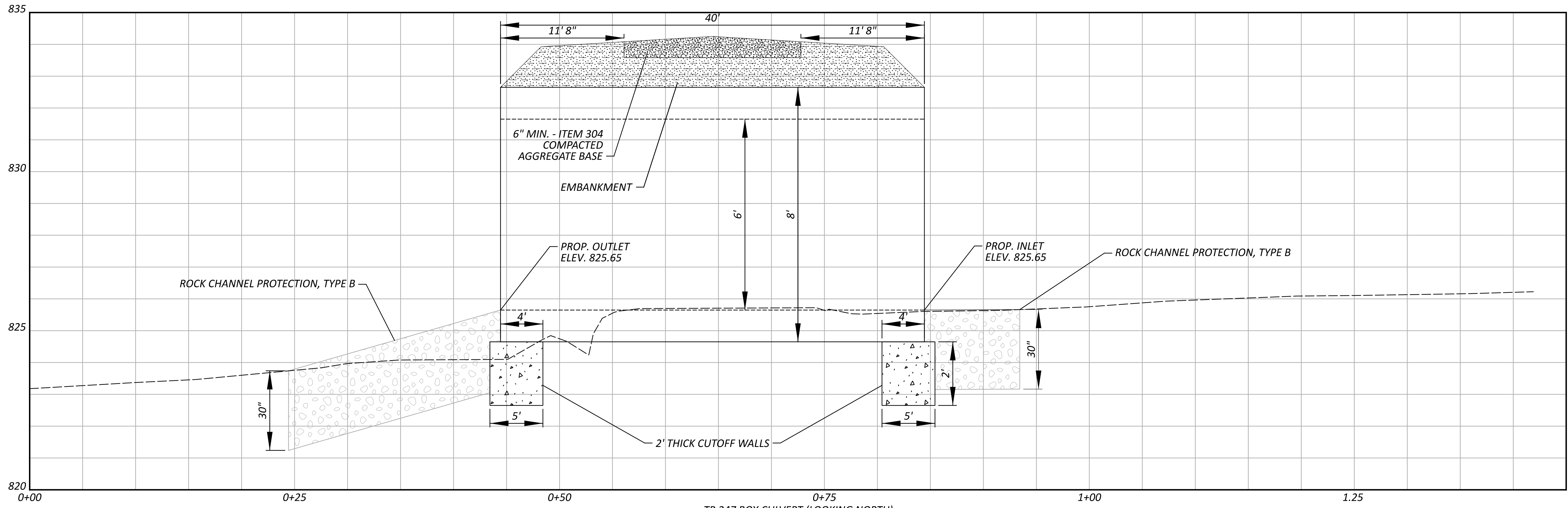

TR 247 BOX CULVERT (LOOKING NORTH)  
 9' X 6' X 40' TYPE A CONDUIT @ 0.00%  
 (VERT: 1" = 1'-8" / V.E. 3:1)

COSHOCOTON COUNTY  
 ENGINEER'S OFFICE  
 (740) 632-2135 FAX: (740) 623-6512

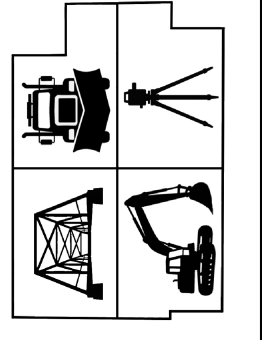

DESIGNER	CJS
REVIEWER	JDK
PROJECT ID	2025050102
SHEET	5
TOTAL	7

C:\ProgramData\Bentley\OpenRoads Designer\2024.00\Configuration\WorkSpaces\OHDOTCEv02\_24.0\WorkSetCFGs\COS-T0247-0001\_Bridgerefplacement\400-Engineering\Drainage\Sheets\2025.11.03\_COS-T0247-0001\_Culvert&FooterPlan-ElevationDetail.dgn

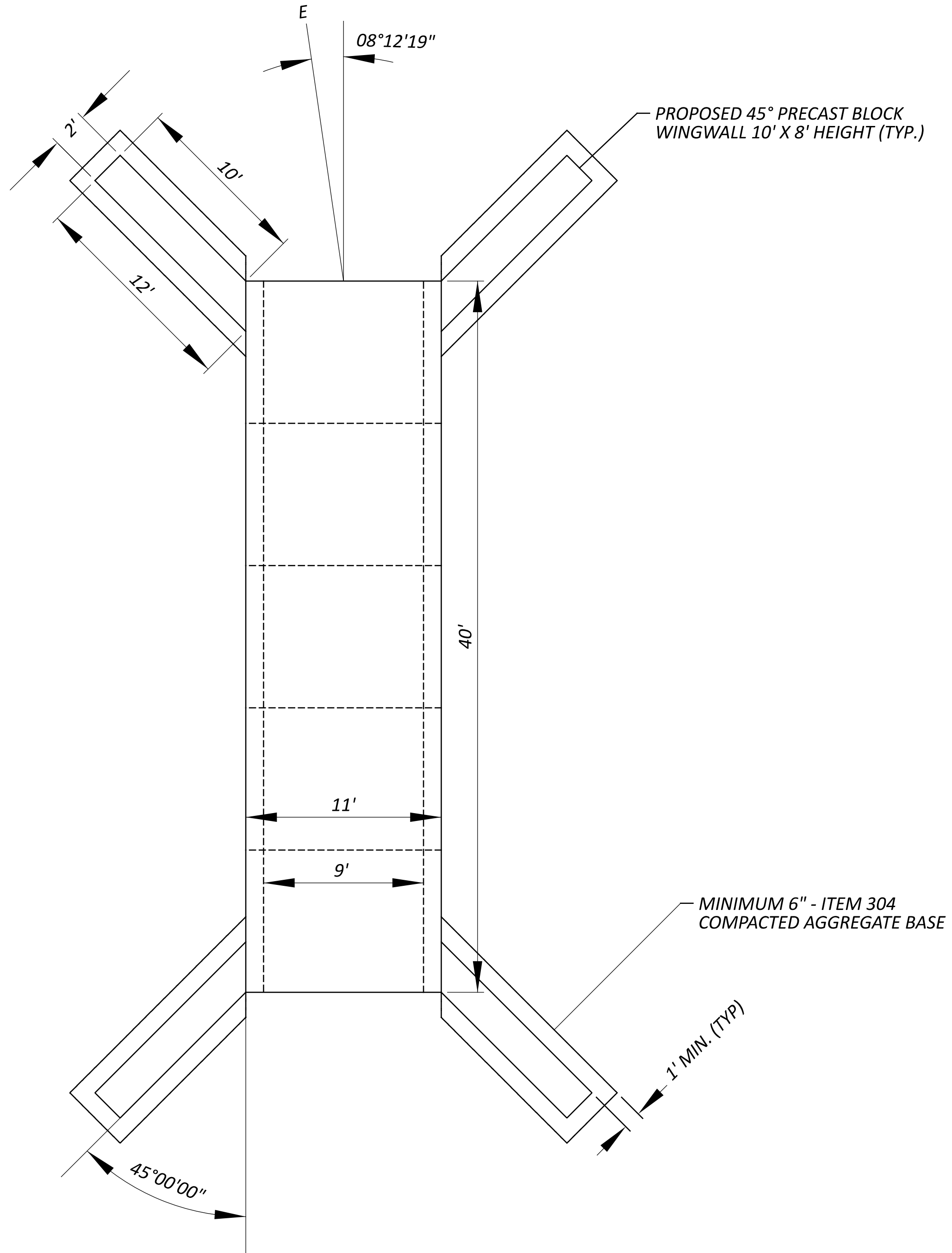
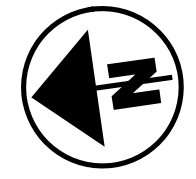

**CULVERT PLAN VIEW**

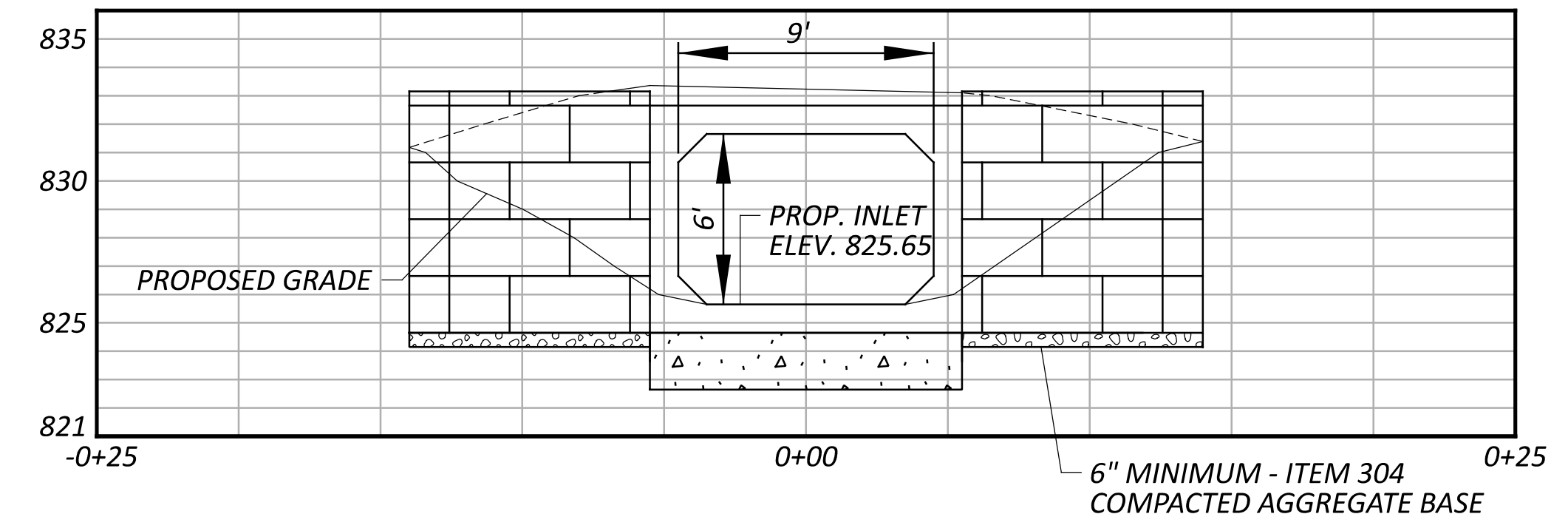

**INLET ELEVATION**  
(VERT: 1" = 5' / V.E. 1:1)  
NOTE: TOP SLAB, BOTTOM SLAB, AND WALL THICKNESSES = 1 FOOT

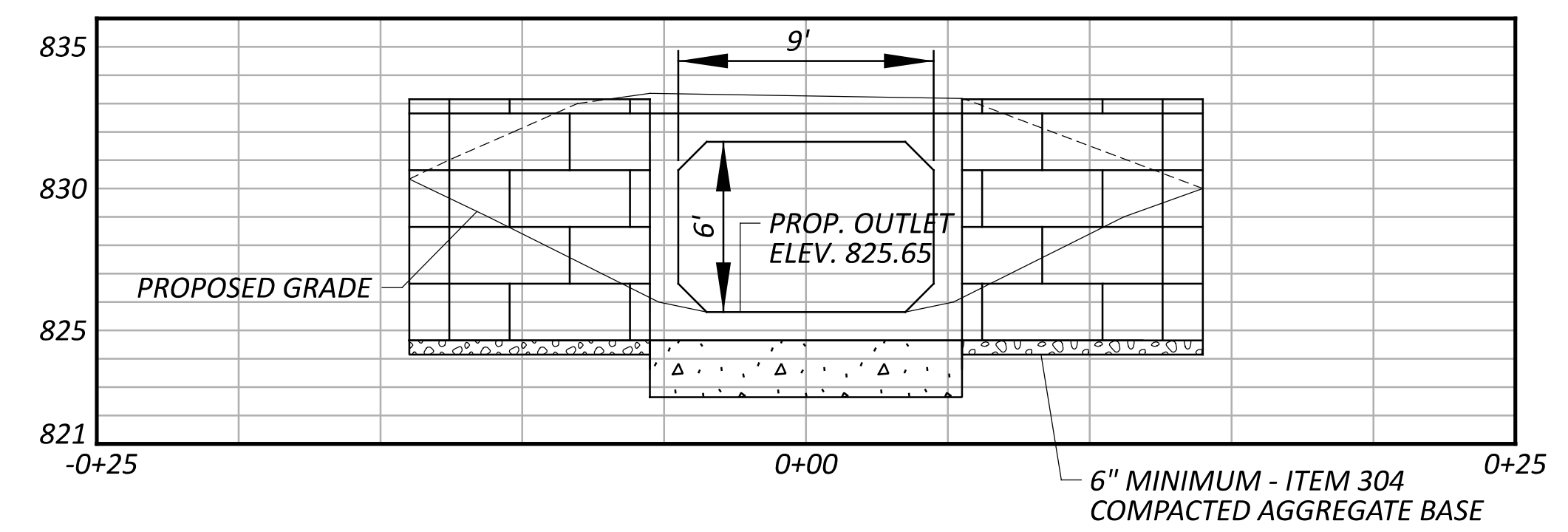

**OUTLET ELEVATION**  
(VERT: 1" = 5' / V.E. 1:1)

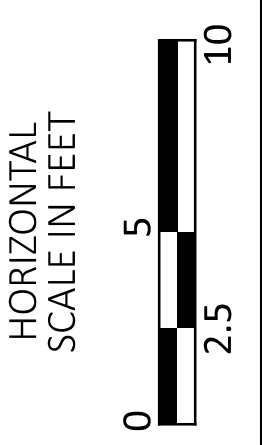

**CULVERT AND FOOTER PLAN / ELEVATION DETAIL**  
**TR 247 BRIDGE 1 REPLACEMENT**

COSHOCTON COUNTY  
ENGINEER'S OFFICE  
(740) 632-2135 FAX: (740) 623-6512

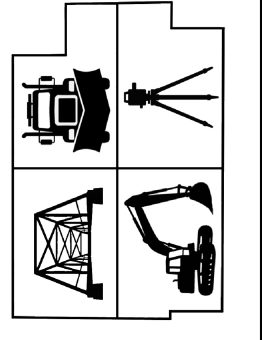

DESIGNER	CJS
REVIEWER	JDK
PROJECT ID	04-07-26
2025050102	
SHEET	TOTAL
6	7

C:\ProgramData\Bentley\OpenRoads Designer\2024.00\Configuration\WorkSpaces\OH\DOTCEv02\_24.0\WorkSetCFGs\COS-T0247-0001\_BridgeReplacement\400-Engineering\Drawings\Sheets\2025.11.03\_COS-T0247-0001\_BoxCulvertDetails.dgn

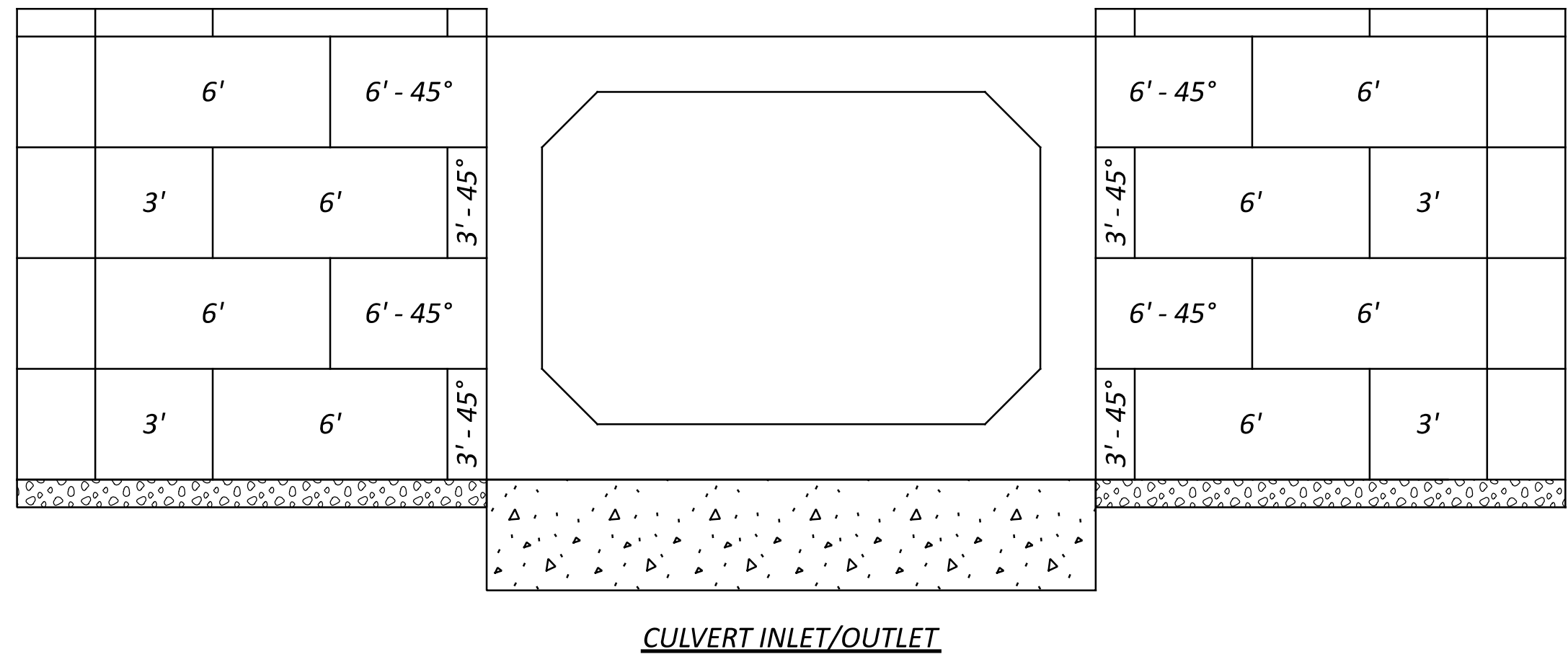

CULVERT INLET/OUTLET

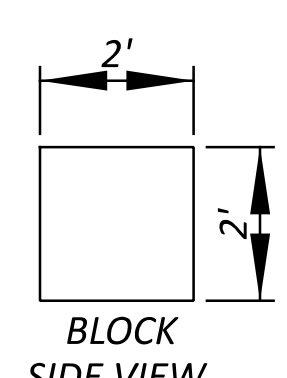
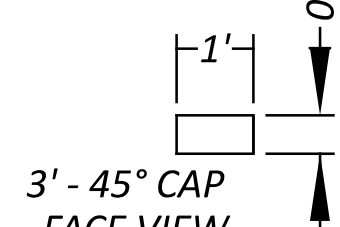
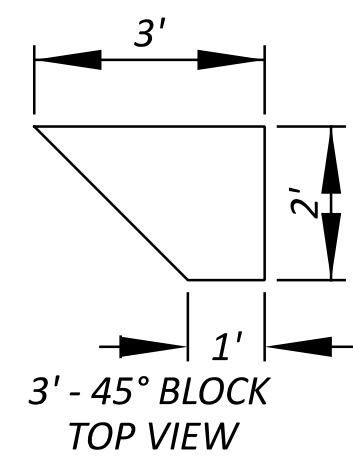
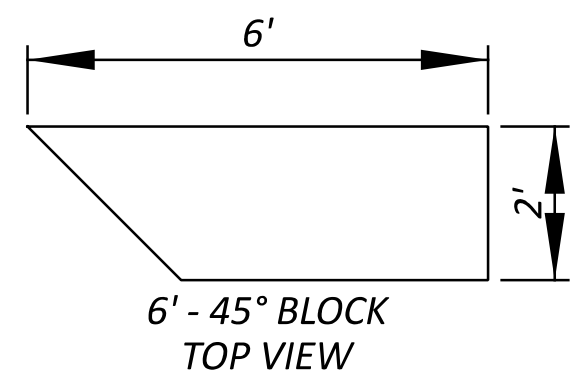
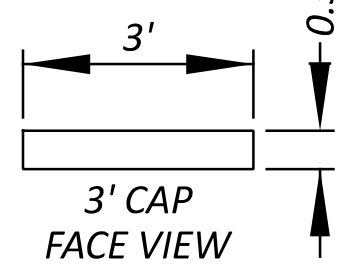
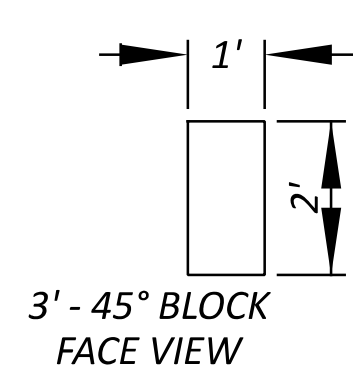
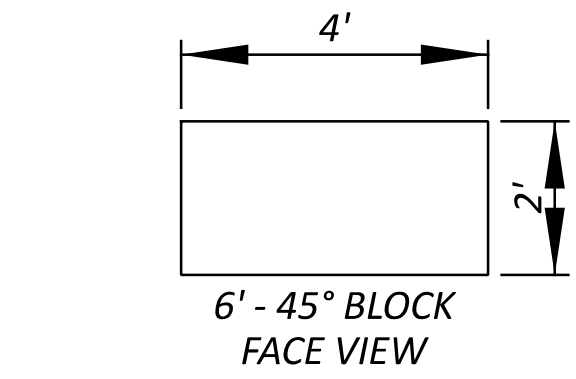
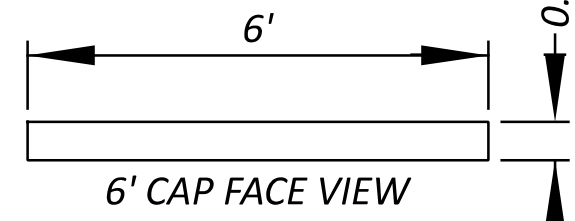
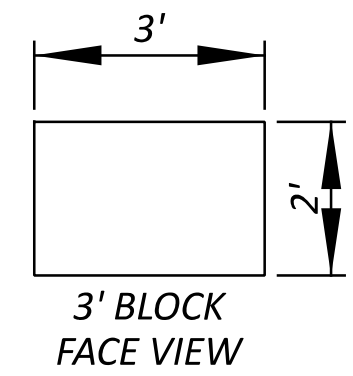
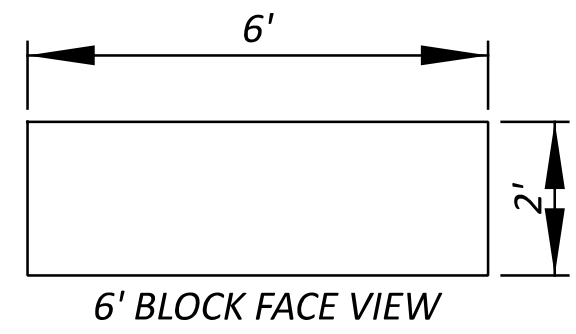

PRECAST CONCRETE BLOCK DETAILS

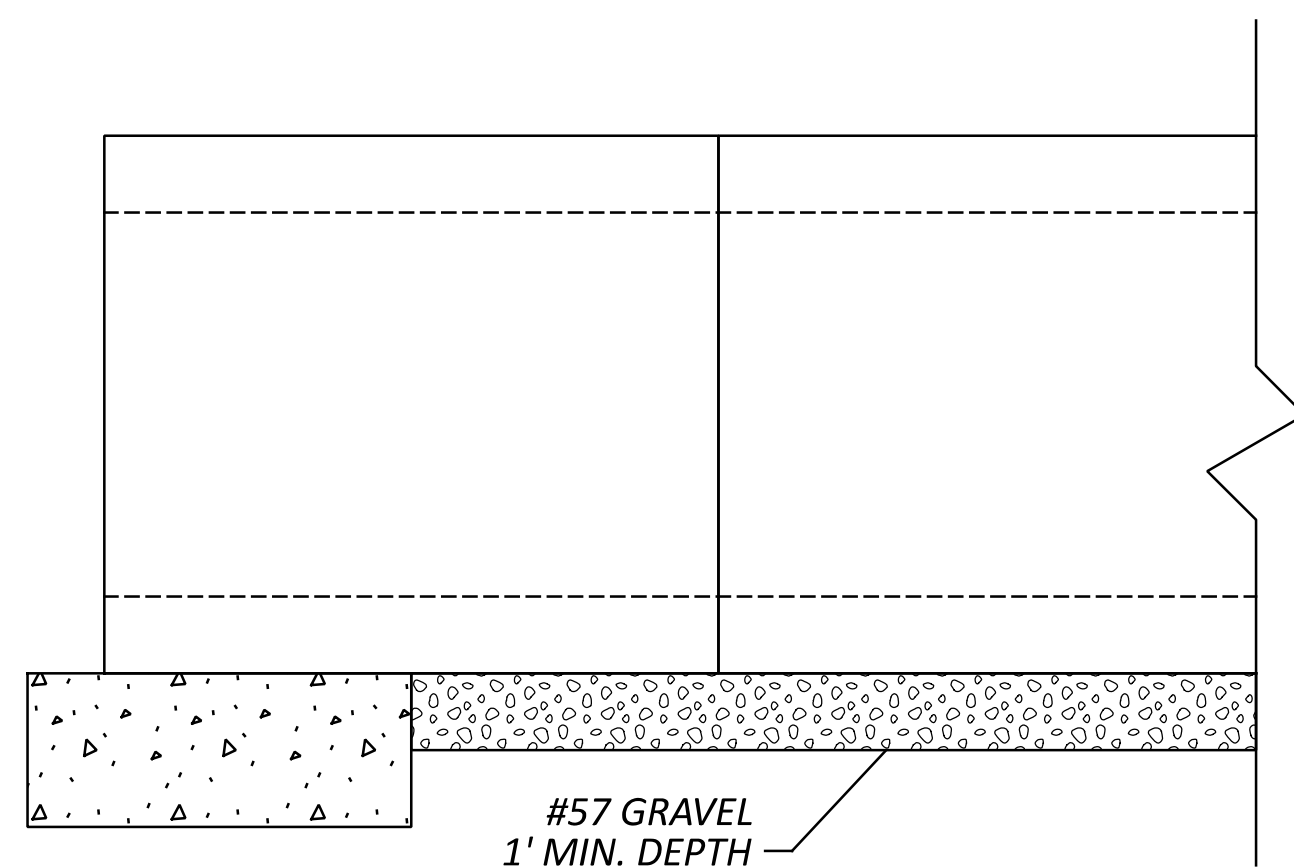

BOX CULVERT BEDDING DETAIL

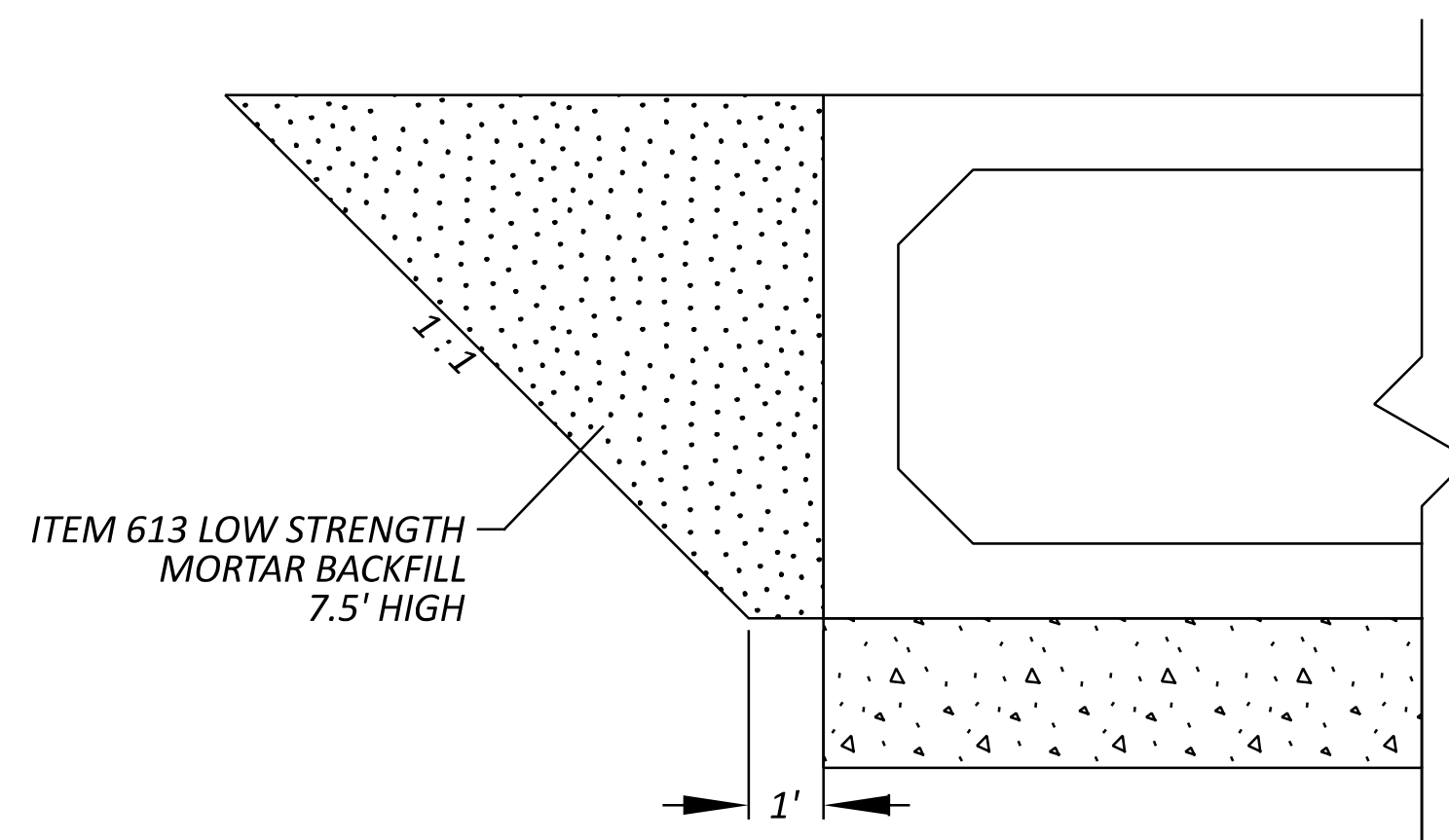

BOX CULVERT BACKFILL DETAIL

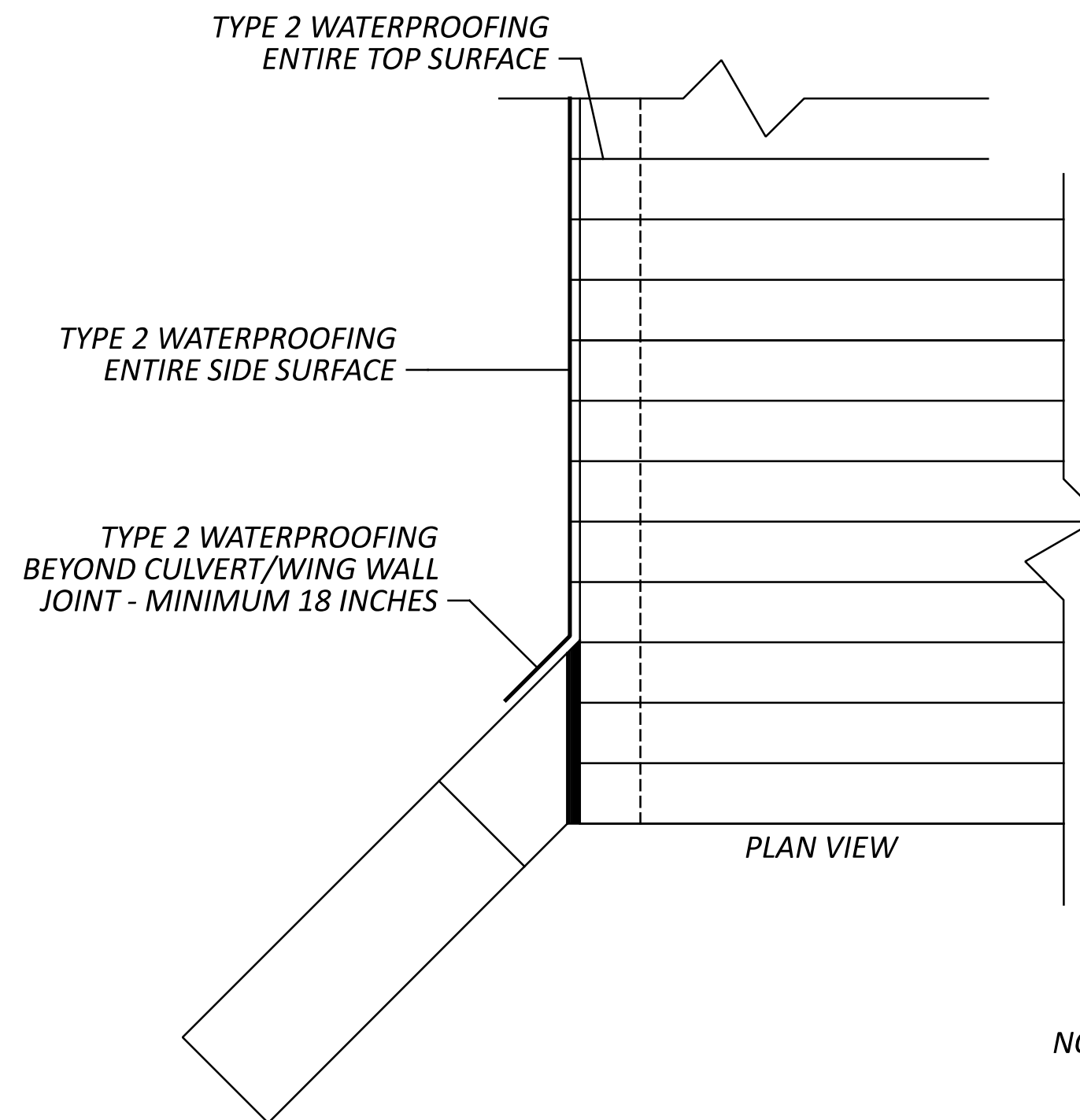

PLAN VIEW

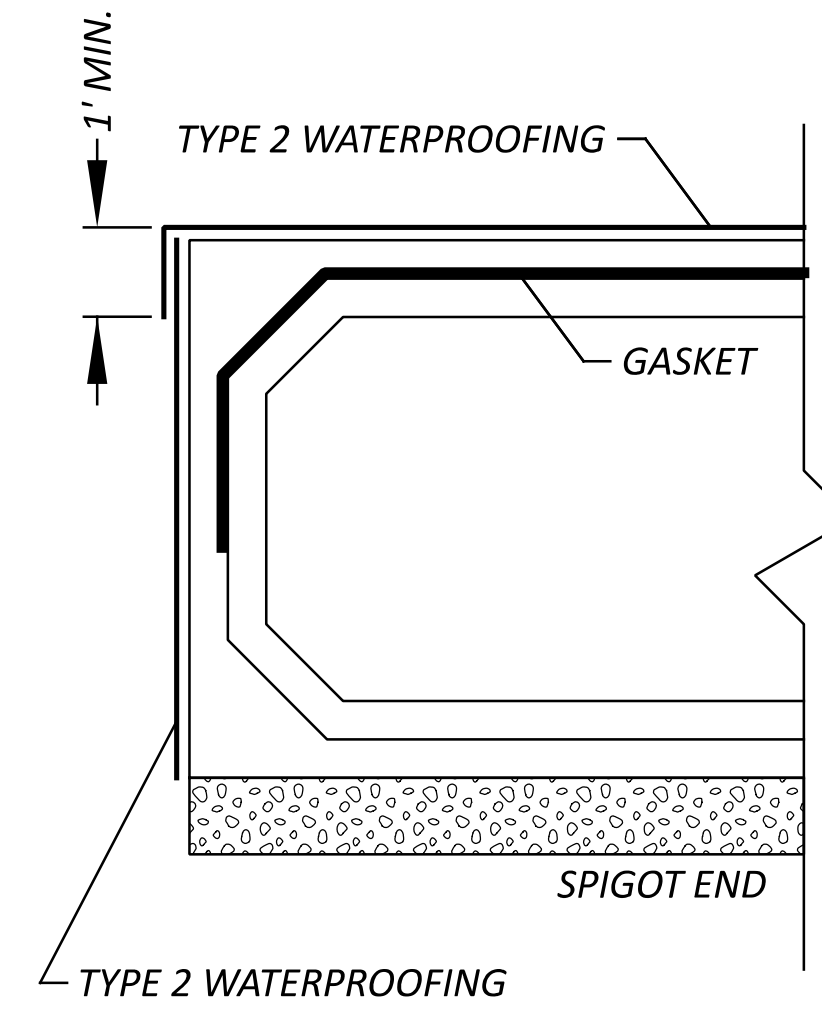
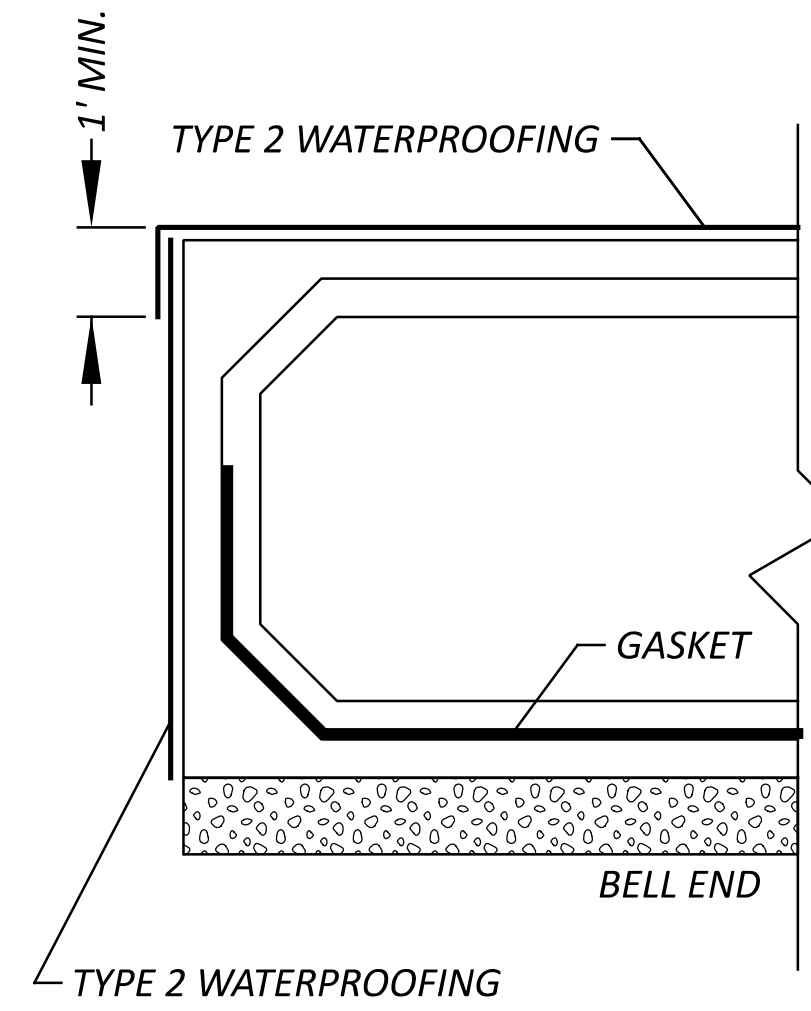

NOTE: SEE ODOT CMS 512.09 AND 711.25 AND MANUFACTURERS SPECIFICATIONS FOR ADDITIONAL DETAILS

WATERPROOFING/SEALING DETAILS

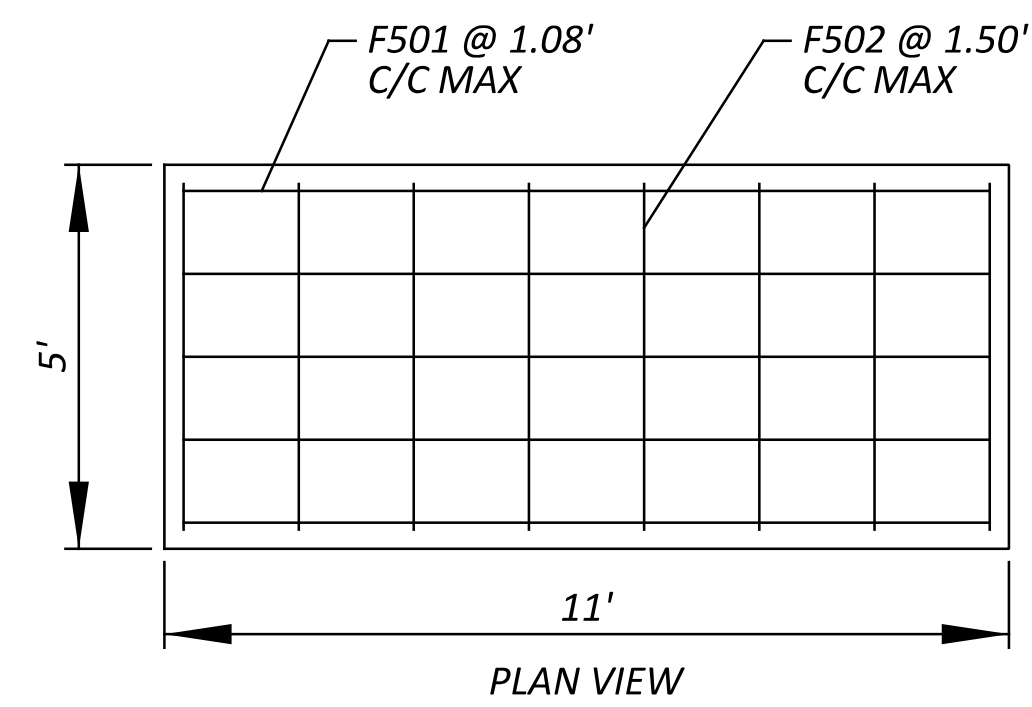

PLAN VIEW

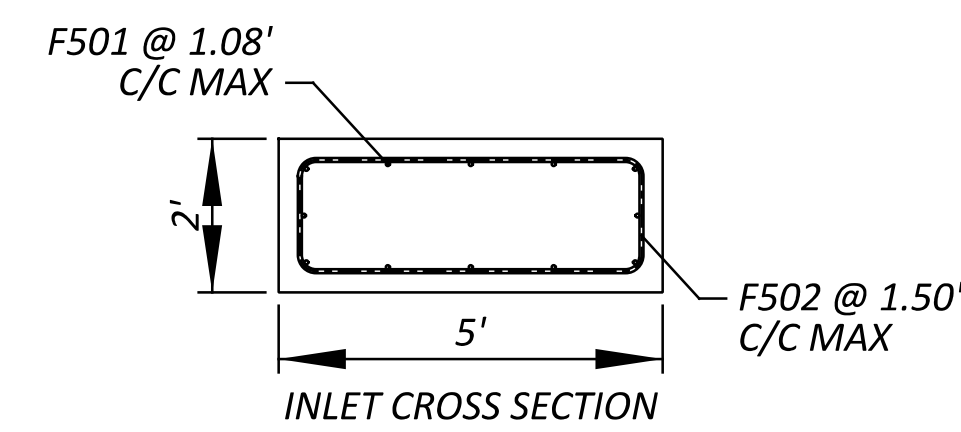

INLET CROSS SECTION

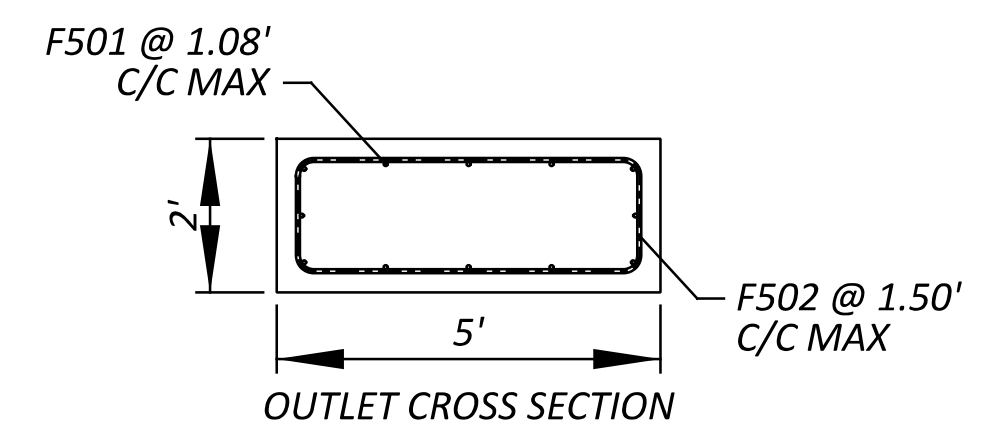

OUTLET CROSS SECTION

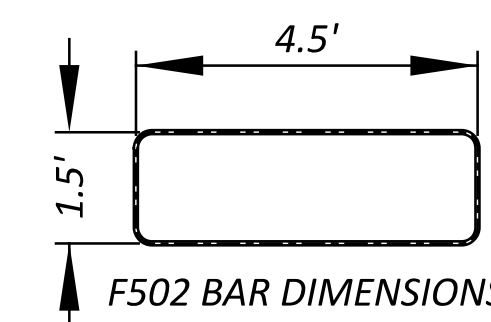

F502 BAR DIMENSIONS

NO. 5 BARS  
F501: 24 @ 10.5' EACH  
F502: 16 @ 12.5' EACH

CUTOFF WALL STEEL DETAILS

BOX CULVERT DETAILS  
TR 247 BRIDGE 1 REPLACEMENT

COSHOCTON COUNTY  
ENGINEER'S OFFICE  
(740) 632-2135 FAX: (740) 623-6512

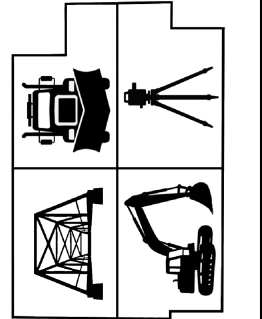

DESIGNER	CIS
REVIEWER	JDK
PROJECT ID	2025050102
SHEET	7
TOTAL	7